

Top 10 Reasons to Move from AutoCAD® to Autodesk® Inventor® 2010

Autodesk Inventor software is the foundation for Digital Prototyping.

The Autodesk® Inventor® 3D model is an accurate 3D digital prototype that enables users to validate the form, fit, and function of a design; minimize the need for physical prototypes; and reduce the type of costly engineering changes that are typically discovered after the design is sent to manufacturing.

Inventor software includes comprehensive tools to generate accurate engineering and manufacturing documentation directly from the 3D model and makes it easy for AutoCAD® software users to realize the benefits of Digital Prototyping by taking full advantage of their investments in DWG design data and AutoCAD software expertise.

Inventor products also offer a wide range of tools to simplify the adoption of and transition to 3D design for AutoCAD software users. All Inventor bundles include the latest version of AutoCAD® Mechanical software for those situations when users just need a high-productivity 2D mechanical drafting tool.

Learn how Autodesk Inventor software is changing the way AutoCAD users think about their design processes.

1. DWG™ TrueConnect

With DWG™ TrueConnect, Inventor software provides read and write of DWG files without translators. Users can leverage their valuable DWG™ data to build accurate 3D part models and produce new documentation in the DWG format that's fully associative to the 3D design.

Experience the benefits of Digital Prototyping with rapid access to native DWG data. Update old 2D drawings by inserting views of new 3D designs to reduce the cost of upgrading existing plants and equipment. And because engineers can save drawings in DWG format, they can easily share insights gained from the digital prototype with partners and suppliers who rely on AutoCAD. Views generated from 3D parts and assembly designs can also be combined with AutoCAD data such as schematics and plant layouts.

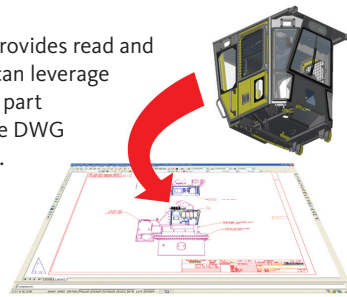

Redesign sub-assemblies in 3D

Generate new part and assembly drawings from the 3D model

Save in DWG

Insert into EXISTING AutoCAD drawings

2. Functional Design

Focus on the functional requirements of a design before committing to creating the model geometry that supports the design intent. Autodesk Inventor products capture the functional requirements of a design to drive the creation of 3D models, enabling engineers to build parts and assemblies based on real-world design input, such as load, speed, and power. With a workflow driven by Functional Design, engineers can rapidly build digital prototypes that validate design functions and catch errors before they reach the manufacturing floor. The result: accelerated design cycles and higher-quality designs.

3. AutoCAD Compatibility

Reduce the time and training required for AutoCAD software users to become proficient in Digital Prototyping workflows by offering a familiar design environment with recognizable icons, AutoCAD-compatible shortcuts, cursor-based prompts, and command redo. User profiles enable engineers to configure Inventor to match the way they work, with out-of-the-box profiles for AutoCAD and Inventor experts. In addition, users can transfer their settings among different computers by exporting the profile to XML.

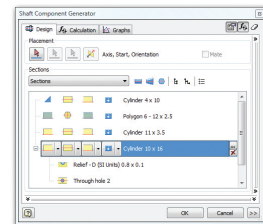

4. Automatic Drawing Updates and Views

Change it once, change it everywhere. Autodesk Inventor associates drawing views to the original components, so a change made to any part or assembly is automatically reflected in all associated drawing sheets. Improve drafting productivity by automatically creating front, side, ISO, detail, section, and auxiliary views of parts and assemblies from the model. Quickly annotate drawings by retrieving the dimension information directly from the design.

5. Integrated Data Management

Autodesk Inventor includes integrated data management with Autodesk® Vault software, a centralized application for workgroups that securely stores and manages work-in-progress design data and related documents. For additional functionality, such as revision control, file and folder security, and BOM and ECO management, learn more about the complete Vault family of products—Autodesk® Vault Workgroup, Autodesk® Vault Collaboration and Autodesk® Vault Manufacturing. Find out more at www.autodesk.com/vaultfamily.

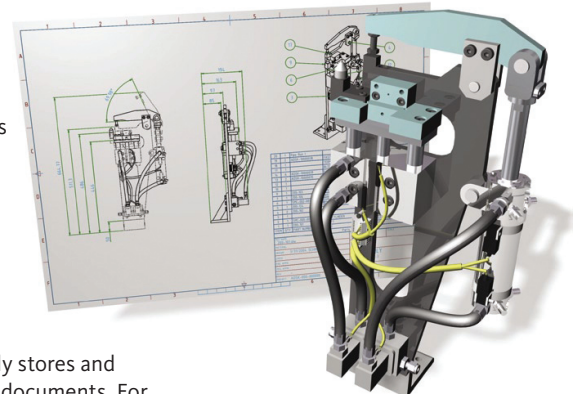

6. Bill of Materials

Create automated and associative parts lists and bills of materials (BOMs) that are developed specifically for manufacturing and that automatically update as the design changes. Support is included for multiple parts lists per drawing, collapsible assemblies, automatic recognition of standard parts, and customizable options so features can be revised to match current company practices. Change a design once, and the updates ripple through the entire drawing to keep everyone on schedule, reducing costly stops in production from incorrect parts counting, identification, and ordering. Export or link BOM data to manufacturing resource planning (MRP), enterprise resource planning (ERP), or data-management systems such as Autodesk® Vault software.

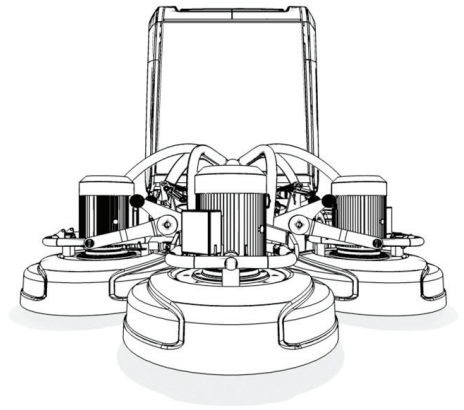

7. Technical Documentation

Quickly create assembly drawings and exploded assembly views for use in training manuals and manufacturing instructions. In the Inventor presentation environment, designers can easily create compelling animated sequences for use in training videos, assembly instructions, and sales presentations, helping them visually communicate their design intent.

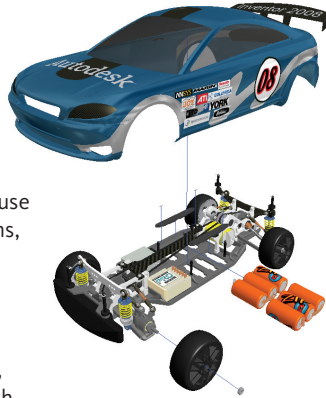

8. State-of-the-Art Rendering

Quickly and easily create high-quality photorealistic renderings, animations, and presentations that improve communication with customers and other decision makers. Autodesk® Inventor™ Studio software provides state-of-the-art rendering, illustration, and animation tools in the Inventor design environment.

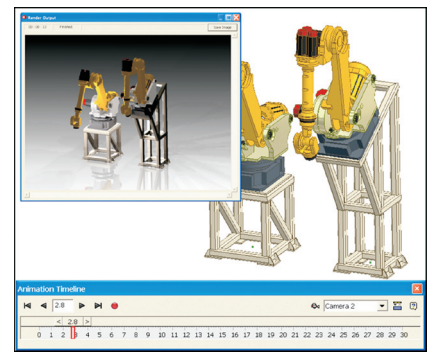

9. Integrated Stress Analysis and Simulation

Create better-quality parts and avoid field failures by using the finite element analysis (FEA) functionality in Autodesk® Inventor™ Professional software to determine stresses and deflections under load. Use FEA to optimize parts strength and reduce material costs without compromising performance.

The dynamic simulation functionality in Autodesk Inventor Professional extends the benefit of the digital prototype, enabling engineers to predict the forces and accelerations experienced by each part in the assembly under real-world conditions with time-varying loads, different friction characteristics, and dynamic components such as springs and dampers.

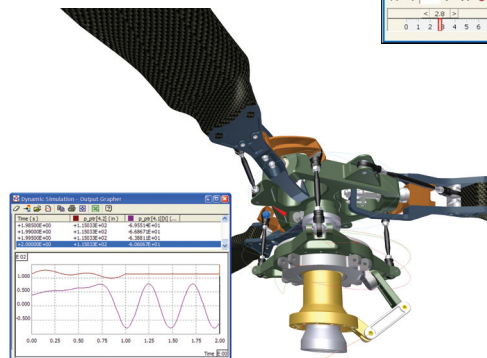

10. Pipe and Cable Routing

Autodesk Inventor Professional software provides the power to quickly and accurately add routed systems, tube and pipe runs, or cables and wiring harnesses to 3D designs. Routed designs automatically comply with user-defined design rules to reduce errors and save time. As with all Inventor files, the assembly drawings automatically update whenever the routing model is modified.

Now Is the Time

Now is the time to take a look at Autodesk Inventor software and experience the benefits of Digital Prototyping at your own pace with the most trusted resource for leveraging and safeguarding your DWG data. With different product configurations that offer specific levels of functionality to fit your design needs, no company is more focused than Autodesk on helping you create accurate digital prototypes and bring better products to market faster at less cost.

For more information about Autodesk Inventor, go to

www.autodesk.com/inventor.

To locate the reseller nearest you, visit

www.autodesk.com/reseller.

